

Errata Sheet

This **errata sheet** concerns errata items for the Series 500 (SDI-12) User’s Manual, dated February 2002.

- Page 5: Insert **3** dashes between "500" and "hhh." The box should read as below:

The sensor will reply with:

<p>a13-KPSI---500---hhh-sssss-vvv</p>	<p>Where: “a” is SDI-12 address “13” is SDI protocol version (read 1.3) “KPSI” is manufacturer “500” is KPSI model number “hhh” is hardware revision level “sssss” is sensor serial number (up to 8 characters) “vvv” is software version</p>
--	---

- Appendix page A-1: Third line; replace 24-pin with 25-pin...
- Appendix page A-2: Replace drawing with the following: (The 25 pin D-shell was erroneously labeled "24 pin.")

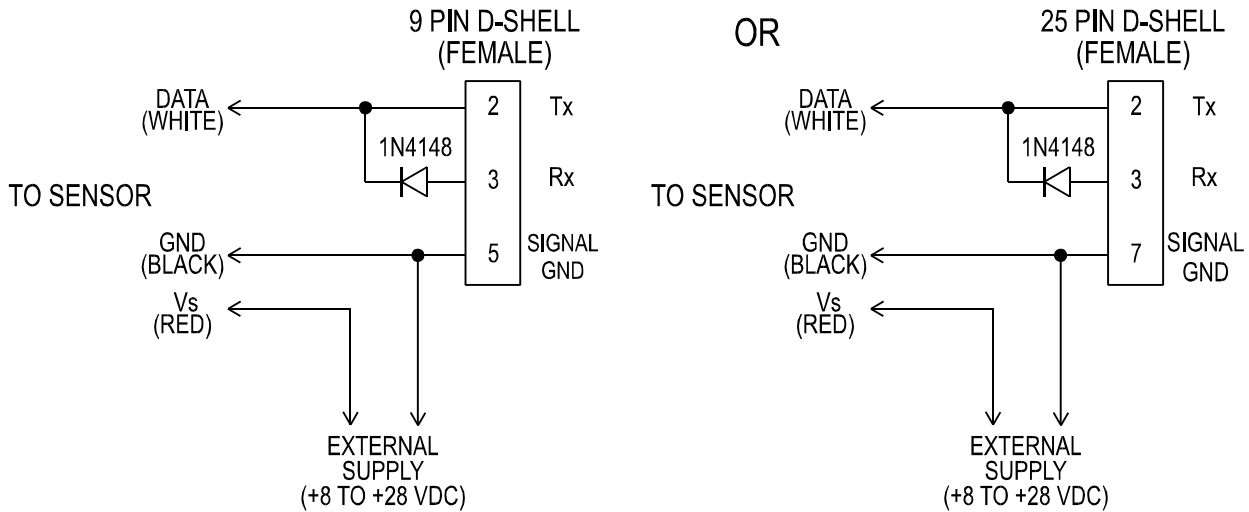

Sensor Connections to 9-Pin or 25-Pin D-Shell RS-232 Serial Port